

Quest

WestminsterLab

Operational Manual

Index

1. Notes to customers, music lovers
2. Cautions
3. Package contents
4. Unpacking and installation
5. Names of parts
6. Setting up
7. Connecting the Quest
8. Optional modules
9. Operation
10. Maintenance
11. Troubleshooting
12. Opinions to obtain best performance
13. Warranty terms
14. Specification
15. Legal information

| Note to customers, music lovers

Thank you for purchasing the Quest pre-amplifier.

Wholeheartedly and sincerely built in Hong Kong, the Quest pre-amplifier crystallizes craftsmanship, skills, simplicity, science and listening experiences.

It is dedicated to every music lover who would like to experience music as it is. Or further, experience music itself.

Sincerely,
WestminsterLab Team

2 Cautions

- I. NO USER SERVICEABLE PARTS INSIDE. Contact WestminsterLab or your dealer if you have service needs.
- II. Do not remove open the pre-amplifier or undo any screws when the unit is still power on or connected to the mains.
- III. WARNING! Do not expose this pre-amplifier to moisture or excessive humidity, and do not use it outdoors. Fire hazard may be resulted.
- IV. Presence of uninsulated “dangerous voltage” within the product’s enclosure may be of sufficient magnitude to constitute a risk of electrical shock to persons.

3 Unpacking & Package contents

Your Quest pre-amplifier should come in one single box. The unit itself and the box should have a matching serial number. In case of discrepancies, please contact your dealer.

Unpacking the pre-amplifier from the box

Please lift the Quest with meticulous care for the unit is about 13kg. It is recommended to move it to a location near the place where it will be installed when the unit is still in its box. Remove all jewellery including watches, rings and belts to avoid damages to the exterior of the Quest during the removal and installation.

If any of the following items are missing, please contact your dealer:

- I. I Quest pre-amplifier
- II. I User manual
- III. I Remote control

4 Installation

Installation and precautions

Before any installation or connection, it is a MUST to make sure the AC mains voltage matches the specification of the unit. (E.g. 100V for Japan, 110V for US, 230V for UK) The AC mains voltage specification & serial number of the specific pre-amplifier are written on the plaque located at the back of the unit and the box that it came from.

Improper input of the AC mains voltage will permanently damage the pre-amplifier and it is not within the warranty conditions.

WARNING! NEVER unplug any cables during operation. It may cause failure or damage to the pre-amplifier, amplifier and speakers. Be sure that both the pre-amplifier and the amplifier are switched off before unplugging any cables. It is even safer to unplug the AC power cord before unplugging other cables.

It is suggested that there is adequate ventilation for the Quest and to place it on a stable and safe surface.

5 Name of parts

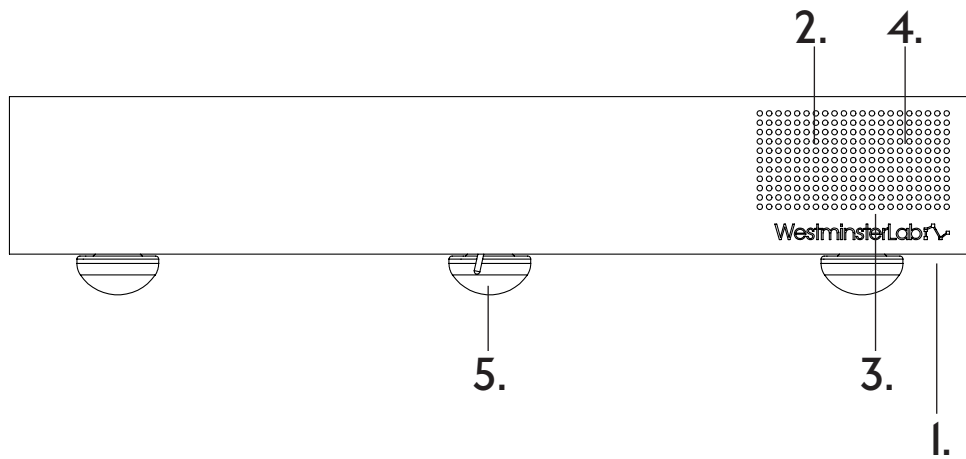

- 1. LED indication
- 2. Volume Display
- 3. IR Recievers
- 4. Input Display
- 5. Ground Mode select

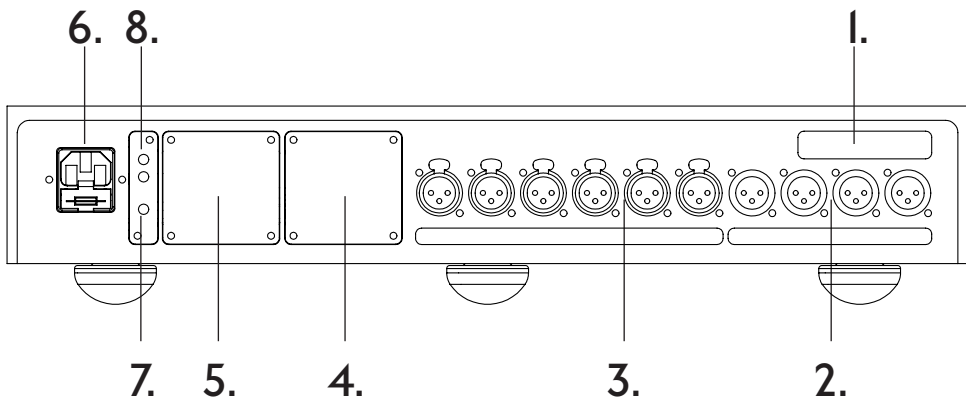

1. Unit serial & Voltage specification
2. XLR output sockets
3. XLR input sockets
4. Option Bay 1 (Input 4)
5. Option Bay 2 (Input 5)
6. AC inlet with fuse cradle
7. Stand-by LED
8. Dual 12V trigger output (Optional)

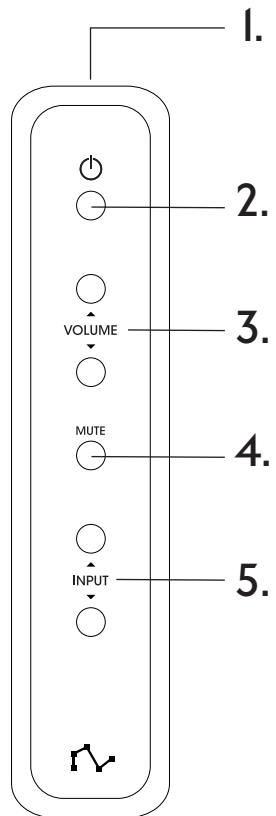

1. IR Port
2. Power On/Off Switch
3. Volume Control
4. Mute/Unmute
5. Input Selection

6 Setting up

Remove the protective fabric bag and place the main unit on the desired operating location. The QUEST does not produce a lot of heat but adequate ventilation is recommended.

Remove the protective bag of the remote control. The remote control comes with two CR2032 button cells pre-installed and should be ready to go.

7 Connecting the Quest

Single / Bi Amplification Operation

Please only use XLR connection between the Quest and the amplifier. Please consult your nearest dealer / distributor if your amplifier only supports RCA connection.

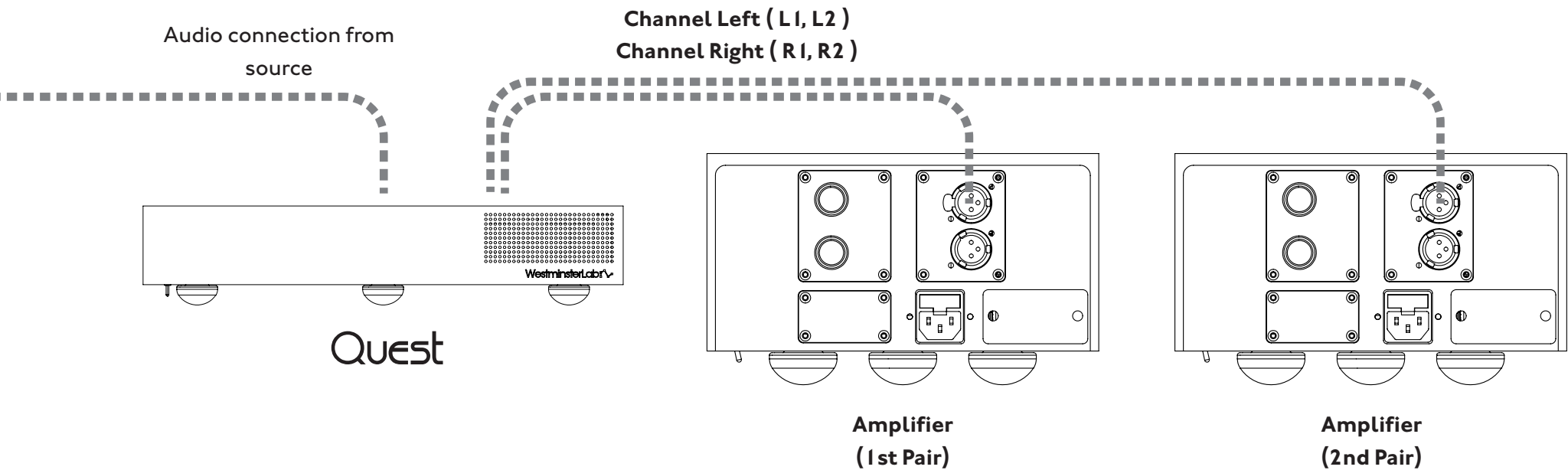

8 Optional Modules

Introduction

There are two bays built into the Quest for optional modules/expansion cards, represented as Input 4 and Input 5 in terms of operation. Please be sure that only modules purchased from WestminsterLab or any official Authorised Distributor and Dealers should be installed into the unit.

WARNING! 3rd Party or Non-certified modules may result in non-reversible damages and will also void the warranty.

Installation

The optional modules are designed to be easily installed by most users. If you have any doubts, please don't hesitate to contact any WestminsterLab dealer and distributor and seek their assistance.

9 Operation

Initial power-up of the Quest

PLEASE be sure that all cables are connected correctly before power-up. Missing or loose input or output cables may cause failure and non-reversible damages to the pre-amplifier, amplifier and speaker.

If RCA connection from the source has to be used, please make sure that you have the optional RCA input module for the Quest.

Upon connecting the power cord, the Stand-by LED in RED located at the back of the unit should light up. Locate and point the remote control towards the front of the pre-amplifier and push the power button on the remote once to switch the unit on.

The volume display should show 00 and the input display should show the number 1, indicating the input 1 is active at the moment. Switch on your amplifiers and start playing something on your source. Choose the right corresponding input by using the buttons on your remote and slowly increase the volume to listening level. Please note that the QUEST only restores the input selection last left upon power cycle, it is by design the volume will always start from zero.

After the power is switched on, the pre-amplifier requires approximately 30 minutes to reach the optimal operating condition. Although the Quest will sound excellent upon initial listening, the sound quality will improve as it warms up.

The feedback we receive leads us to recommend at least 200 hours of burn-in on the Quest. Customers generally report improvement up to two months.

During operation

The Quest requires no adjustments during normal operation. If there is no sound or the sound quality is in some way impaired, consult the “Troubleshooting” section in this manual.

WARNING! NEVER unplug any cables during operation. It may cause failure or damage to the QUEST, amplifier and speakers. Be sure that the Quest is off with no LED illumination in the front before unplugging any cables. It is even safer to unplug the AC power cord before unplugging other cables.

Ground Mode select

The toggle located at the bottom of the Quest allows user to select which grounding mode the Quest is operating. The dynamic grounding technology employed in the unit allows the user to tailor their Quest grounding behaviour on the fly.

By default, the toggle switch is on Mode I (handle on the right hand side). Mode I is a less aggressive mode in terms of grounding and it should yield great results with most systems in the world. Mode II (handle on the left hand side) brings more body, texture, speed and microdynamics to the music, but it may also bring slightly more noise to some systems.

10 Maintenance

Maintenance & cleaning

The Quest requires no user maintenance other than to keep it clean. It is recommended to use a very soft cloth to gently wipe the Quest's surface without any liquids or solutions. To maintain the best exterior, please keep the surface from oil and grease. Be aware not to scratch the surface of the unit.

Services

Please contact your nearest WestminsterLab distributors or dealers for services / overhaul on the Quest.

|| Troubleshooting

Quest does not power up

If the red LED located at the rear of the Quest is not illuminated, follow the procedure below. If one step succeeds in activating the power, stop and ignore the other steps.

Check if the AC mains voltage matches the specification of the Quest. Do not connect the AC power cord if they do not match. This will damage the unit permanently. Always use a power cord with ground wire connected.

1. Check that there is power from the wall outlet.
2. Check to make sure the AC cord is plugged into the wall outlet.
3. Check the back of the Quest to make sure the IEC connector is pushed all the way into the socket on the back of the unit.
4. Unplug the power cord and check if the fuse is blown (Both power cord and the back of the Quest). Replace with the same type and rating only.
5. Check your household electrical box to make sure the circuit breaker has not been tripped. If it has, flip the breaker back on.
6. If the breaker trips again, make sure the power cord has no damage and can work properly. You may try the power cord by using it with other home appliances. Change the power cord if it is not working.
7. If all of these steps fail to return power to the Quest, consult your dealer or distributor for service.

Red LED at the rear is illuminated and front display fails to turn on

The red LED at the back of the unit indicates the unit receive power from the outlet and the unit is currently on standby. By pressing the power button on the remote control, the unit should switch on. A white LED behind the logo of WestminsterLab and both display at the front of the Quest should power on.

1. Power cycle the amplifier completely by completely removing the power cable of the Quest and plugging it in back again
2. Make sure the you point the IR blaster of the remote control directly to the front of the Quest. The IR blaster and receiver are both designed to be very sensitive. However, a line of sight is preferred for best performance.
3. Make sure the battery of the remote control is not depleted. You can use your camera on your phone to observe the IR blaster window of the remote control. You should be able to see the IR blaster flicker when a button is pressed. You can swap out the two CR2032 button cells of the remote control by removing the screws at the bottom of the remote.
4. If all of these steps fail, consult your dealer for service.

Front LED and display are illuminated but you hear no sound

Switch off the amplifier first. Follow these steps in order. If one step succeeds in restoring the sound, stop there and ignore the other steps.

1. Check if the correct input has been selected on the Quest.
2. Check if the volume is at a reasonable level (10-20) and not muted (--).
3. Check all the cables within the system, make sure they are properly connected and that the cables are not damaged or shorted.
4. Check your source device and power amplifier to make sure they are both turned on.
5. Check the source device to make sure there is a signal output, i.e. if it's a record player, make sure it's spinning and the tonearm is lowered, or if it is a CD player, make sure it is in play mode and not in pause, or file playing for computer/network streamer/file player. If the source has volume control built-in, make sure it is off and at maximum volume.
6. Try using another pair of interconnect cables (even cheap ones will work temporarily) instead of the ones being used between the source device and the preamp and between the preamp and the amplifier. If this restores sound, replace the defective cables.
7. Try using another pair of speaker cables (even cheap ones will work temporarily). If this restores sound, replace the defective cables.
8. If all of these steps fail to restore sound, consult your dealer for service.

12 Opinions to obtain best performance

- I. Place on a rigid, stable, heavy mass surface.
- II. Warm up for more than 45 to 60 minutes.
- III. Put the Quest as close as possible to the sources and keep the cable as short as possible. It is preferable to use a long balanced interconnect cables to the amplifier and keep the sources cable as short as possible. We highly recommend WestminsterLab cables to obtain the best experience and performance.
- IV. It is recommended to use a dedicated AC power cord rated at a minimum of 3 amps for 230V mains, or 5 amps for 110V mains. We highly recommend WestminsterLab power cables to obtain the best experience and performance.
- V. The power supply of the Quest has been meticulously designed to deliver the utmost performance. From our experiences, power conditioners and also regenerators are not recommended for the Quest.

13 Limited Warranty

WestminsterLab warrants the Quest pre-amplifier against manufacturing defects and defects in materials for three years from the date of purchase from an authorized WestminsterLab dealer, subject to the conditions listed below:

1. The warranty covers only new Quest pre-amplifier (product or products) by WestminsterLab purchased from an authorized WestminsterLab dealer.
2. The warranty is non-transferable and is valid only for the original purchaser.
3. The warranty is valid only if the product has been used according to the instructions in the owner's manual. Damage due to accidents, owner abuse or negligence is not covered under this warranty.
4. All services must be performed by an authorized WestminsterLab dealer. Damage resulting from service by other parties is not covered under this warranty.
5. All products returned for service must be packaged in the original container and must include an original / photocopy of the original purchase receipt. If the original container has been lost or discarded, contact WestminsterLab or WestminsterLab distributors or dealers for a replacement.
6. If the product must be shipped back to WestminsterLab for warranty service, the customer shall bear the shipping costs. WestminsterLab will pay for return shipping.
7. Before shipping the product to WestminsterLab for service, the customer must first obtain a Return Authorization (RA) number from WestminsterLab. The RA number must be marked clearly on the side of the package.

8. WestminsterLab has the right to choose whether repairing the product by using new or refurbished parts.
9. This warranty covers only defects in products made by Westminster-Lab. It does not cover incidental or consequential damages, force majeure, or damages to other products resulting from defects in WestminsterLab products.
10. Your authorized importer or dealer bears the direct responsibility for warranty coverage of your amplifier. Please contact your importer or dealer with requests for service under warranty. WestminsterLab will work with your importer or dealer to assure that the terms of the warranty are fulfilled.

14 Specification

QUEST

Distortion

<0.0001% @ 1 kHz

Signal-to-Noise Ratio

> 120 dB, unweighted

Inputs

3 sets of balanced XLR inputs

2 optional modules

Input Impedance

51 k Ω

Input Voltage

6V_{rms}

Frequency Response

2Hz to 100 kHz, ± 0.1 dB

Outputs

2 sets of balanced XLR outputs

Output Voltage

12V_{rms}

Channel Separation

> 120dB

Gain

6.5dB

Volume Control Range

0 to -63dB / Mute

Dimensions

W470 x H110 x D392 mm

Weight

13.1KG

15 Legal information

The information in this owner's manual is subject to changes without notice. The current Version V I.0 of this manual was produced by the WestminsterLab Ltd..

The information in this manual is the sole property of WestminsterLab Ltd.. Any reproduction in whole or part without the expressed written permission of WestminsterLab Ltd. is prohibited. No material herein may be transmitted in any ways including either electronic or mechanical methods for any purpose without expressed written permission of WestminsterLab Ltd..